

LED POWERLINE LC



FEATURES

Irradiation width due to application
(76 mm – 3.000 mm)
Max. irradiation intensity: up to
25.000 mW/cm²
Wavelength:
365, 385, 395 and 405 nm
Water cooled

- High irradiation power
- Very small dimensions / different lengths
- Low weight
- Different wavelengths available

BENEFITS

- Low temperature load
- No warm-up phase
- Appropriate for clean rooms

LED POWERLINE LC

The LED Powerline LC has been developed for all applications requiring a highly intensive UV irradiance with a low temperature load on the substrate. The LED assembly, as well as an electronic power control, guarantee high intensity and homogenous distribution of light. The recognition of LED-malfunction and a comprehensive monitoring function provide for very high process stability. So, especially in fully automated production lines, repeatable results can be realised even in shortest cycle times. The typical service life of a LED is longer than 20.000 hours*. The LEDs can be switched on and off as often as necessary. They do not require a warm-up or cooling phase. The emitted wavelengths are available in 365/385/395/ 405 nm +/- 10 nm. It is thus possible to adapt the LED head to any application in question.

APPLICATIONS

The LED Powerline LC controlled either by LED powerdrive or Hoenle controller is appropriate for various applications, such as

- Bonding, fixing or encapsulating of components in the electronic, optical or medical sector
- Fluorescence stimulation for materials testing and picture processing
- High-intensity UV irradiation in the chemical, biological and pharmaceutical sector
- intermediate and final curing in printing applications

LED CONTROL

The adjustment of the irradiation time is freely selectable in the ranges of 0.01 – 99.99 sec. or 0.1 – 999.9 sec pr 1 – 9999 sec. Alternatively, continuous operation can be chosen. The operating status and the temperature of the LED segments as well as the irradiation time can be seen on the Hoenle powerdrive display at a glance.

The electrical LED power can be adjusted between 2 % and 100 % in 1 %-steps. The device is recording the LED operating hours and the service menu gives comprehensive information about the current operation status.

The following functions are available when operating with Hoenle LED Powerdrive:

- Large and clear display with all relevant information
- Intelligent power control
- Temperature / error control of LED
- Shortest cycle time 0,01 s
- LED powerdrive control 80 for LED Powerline 80 resp.
- LED powerdrive control 120 for LED Powerline 120
- Monitoring of LED segments regarding short-circuit, interruption and excess temperature
- Auto recognition of connected LED Powerline LC
- LED Powerline 80 has got 2 LED segments, whereas LED Powerline 120 owns 3 LED segments

PROCESSFLOWCONTROL

It is possible to program complete process sequences, e.g. different exposure series including holding times, on the PC, which can be transmitted on the LED controller later on. Due to the ProcessFlowControl even complex irradiation functions without additional SPS can be realized.



INTERFACES

The LED powerdrive controller has the following interfaces:

- Analog preselected target value 0,2V – 10V □ 2% – 100%
- PLC inputs: LED on, LED enable
- PLC outputs: LED is on, LED is off, LED error, LED warning
- Dry relais contact function (see PLC outputs) or for driving an external cooling device
- Foot switch
- LED enable signal

ADVANTAGES OF THE LED TECHNOLOGY

LEDs do not emit IR radiation. Even temperature-sensitive materials can be irradiated. The different spectra available guarantee safe and fast curing. As LEDs do not require a warm-up phase, LED heads can be switched on and off without any problems: they are ready for immediate operation.

TECHNICAL DATA

LED service life	> 20.000 hours*
adjustment range of timer	0,01 – 99,99 or 0,1 – 999,9 or 1 – 9999 sec. or continuous operation
wavelengths in nm typical intensity in mW/cm ² **	365 385 395 405 14.000 20.000 25.000 25.000
power supply LED powerdrive	90 V – 264 V, 47 Hz – 63 Hz
max. input current	2,2 A
irradiation area ***	ca. 76 x 10 mm or ca. 114 x 10 mm
dimensions LED-head without connectors (H x B x T)	ca. 86 x 20 x 50 mm or ca. 124 x 20 x 50 mm

* typical lifetime under specified operating conditions

** measured with Hoenle LED sensors for UV meter

*** other lengths up to 3.000 mm upon request

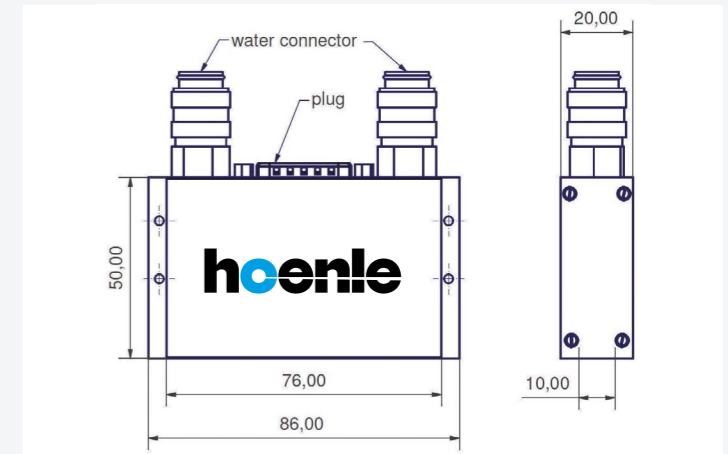

Powerline 80 mm

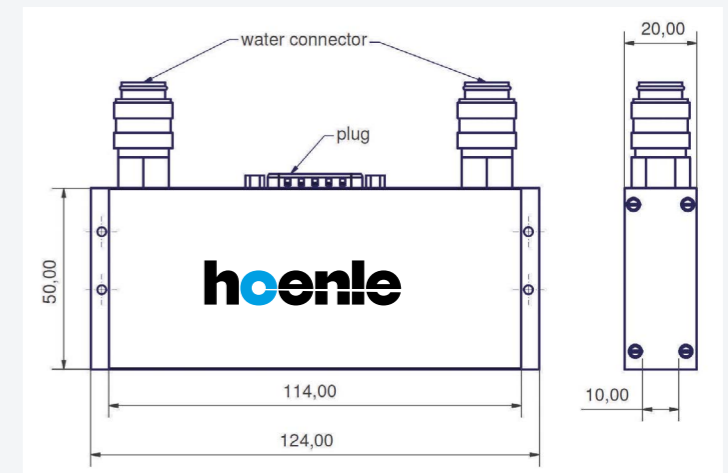

Powerline 120 mm

MORE HOENLE LED-UNITS

Water cooled type 

Air cooled type 



LED Spot W

The LED Spot W allows an extremely high UV intensity output – and requires only a very small amount of space.



jetCURE LED

Modularly controll- and changeable (grid 41 mm) as well as continuously adjustable. Available in two versions which differ in their cooling air duct.

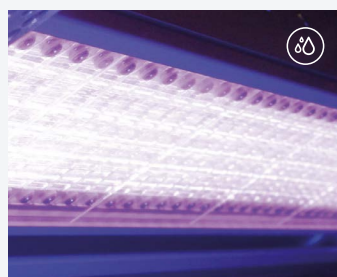

LED Powerline Focus

Almost distance-independent high intensity due to focusing optics.



bluepoint LED eco

bluepoint LED eco has been developed for all applications requiring a most intensive punctiform UV irradiation.



LED Spot 40 IC

The LED Spot 40 IC was developed for all applications requiring a compact flood unit with high intensities.



LED Power Pen 2.0

This handy LED point source is available in the wavelengths 365 nm and 405 nm. Depending on the wavelength it is able to generate UVA-intensities of either 10.000 mW/cm² or 16.000 mW/cm².

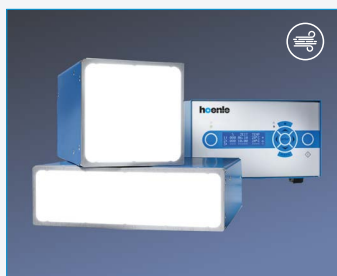

LED Spot 100 IC / 100 HP IC & LED Spot 200 HP IC

The light-emitting aperture has a size of about 100 x 100 or 200 x 50 mm. For bigger irradiation fields, several LED Spots can be arranged modularly.



UVAHAND LED

A high-intensity hand-held UV lamp. It is easy to transport, ergonomically designed and ideal for mobile use.

Hoerle Eleco

125, av Louis Roche
Z.A. des Basses Noels
92238 Gennevilliers Cedex
France

T. +33 1 47 92 41 80
eleco@hoenle-eleco.com

www.hoenle-eleco.com



DIN EN ISO 9001
DIN EN ISO 14001

Operating parameters depend on production characteristics and may differ from the foregoing information. We reserve the right to modify technical data.
© Copyright Hoerle Eleco. Updated 12/25